

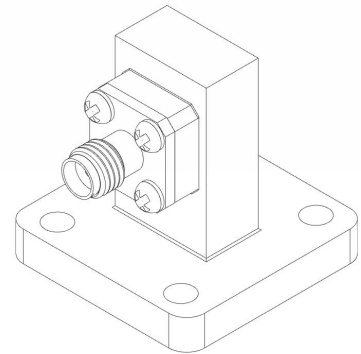

CWR51SC SMA/Female to WR51 Coaxial to Waveguide Adapter 15-22 GHz

Rev 001

Electrical	
Frequency	15-22 GHz
VSWR	1.20
Impedance	50 Ohms
Mechanical	
SMA Interface per	MIL-STD-348B
Materials	
Body	Cu
Body(SMA)	Passivated Stainless Steel
Contact	BeCu
Contact Plating	Au 50 μ " Min
Dielectric	PTFE
ROHS Compliant	



Related Links	
Typical Data	Product Page

